

Best viewed in landscape mode



THE i3



THE i3s



THE BMW i3 AND i3s.

RETURN BY CLICKING [🏠](#)
SELECT A TOPIC BELOW TO EXPLORE:



FEATURED MODELS.

THE BMW i3:

BMW eDrive electric motor, 170hp (125kW), 20" BMW i light alloy Double-spoke style 430 wheels with mixed tyres, exterior paint in Imperial Blue with Frozen Grey metallic highlight, seats in Solaric wool cloth/leather combination, BMW i Lodge interior world with Dark Oak wood, matt interior trim.

THE BMW i3s:

BMW eDrive electric motor, 184hp (135kW), 20" light alloy Double-spoke style 431 wheels, Jet Black with mixed tyres, exterior paint in Fluid Black with BMW i Blue highlight, seats in Dark Truffle Vernasca leather, BMW i Suite interior world with Dark Oak wood, matt interior trim.

Content correct at time of publishing (as of November 2020). Prices and technical data subject to change. The models shown on these pages may feature optional equipment. Standard equipment may also vary depending on engine variant. For further details, please contact your local BMW Centre.



"THE BMW i3 IS A GENUINELY IMPRESSIVE TAKE ON THE ELECTRIC CITY CAR."

EVO

[Read the full review](#)

"ON THE ROAD, THE i3 IS FUN TO DRIVE, WITH RESPONSIVE ACCELERATION, CRISP STEERING AND NEAR-SILENT RUNNING MAKING IT PARTICULARLY EFFECTIVE AT DARTING AROUND TOWN."

DRIVING ELECTRIC, AUGUST 2020

[Read the full review](#)





"WHILE THERE ARE GRADUALLY INCREASING NUMBERS OF EV AND ALTERNATIVE POWERTRAIN VEHICLES ON SALE IN THE UK, FEW CAN MATCH THE ROAD PRESENCE AND SENSE OF INNOVATION THE i3 PROVIDES."

AUTO EXPRESS, MARCH 2020

[Read the full review](#)



THE BMW i3 120Ah.



The BMW i3 120Ah is shown above in Imperial Blue metallic paint with Frozen Grey highlight and optional 20" BMW i Double-spoke style 430 wheels in Bicolour.

■ Standard equipment □ Optional equipment

THE BMW i3 120Ah.



EXTERIOR

- 19" BMW i light alloy Turbine style 429 wheels, Bicolour
- LED headlights
- Dynamic brake lights
- Exterior mirrors, electrically folding with anti-dazzle
- Carbon fibre reinforced plastic (CFRP) body structure
- A-pillar and roof moulding in High-gloss Black and Chrome optic highlight
- Exterior mirror caps in High-gloss Black
- Rear spoiler, Black with integrated LED brake light
- Kidney grille, High-gloss Black with Chrome contrast edging

INTERIOR

- Seat heating, front
- Heat protection glazing with green-tint
- Extended storage
- Aragats Grey / Black Neutronic cloth upholstery
- Multi-function leather steering wheel, two-spoke – Black with unique BMW i Blue accent
- Interior trim, Andesit Silver metallic effect
- Interior world, Atelier
- Slide through light-weight front seats, with contrast highlighting in BMW i Blue

SAFETY & TECHNOLOGY

- Park Distance Control, rear
- Rain sensor with automatic wiper and headlight activation
- Conditioned Based Servicing
- Remote control, including integrated key

BATTERY & CHARGING

- Digital Charging Service (12 months as standard)
- 2.4kW AC charging
- AC fast charge cable
- Li-Ion Battery with active cooling with 38kWh usable energy content
- BMW eDrive motor
- DC Rapid Charge preparation
- Fast charging AC multi-phase capability
- Illuminated charging socket with visual display of charge status

AUDIO & COMMUNICATION

- Navigation system –BMW Professional Multimedia
- Apple CarPlay® preparation
- BMW ConnectedDrive Services, comprising:
 - BMW Apps interface
 - BMW Emergency Call
 - BMW Online Services
 - BMW TeleServices
 - Connected eDrive Services
 - Real Time Traffic Information (RTTI)
- Bluetooth hands-free facility with USB audio interface
- DAB digital radio
- BMW Professional radio without CD player



THE BMW i3s 120Ah.



The BMW i3s 120Ah is shown above in Fluid Black non-metallic paint with BMW i Blue highlight.

■ Standard equipment □ Optional equipment

THE BMW i3s 120Ah.



In addition / replacement to i3 models

EXTERIOR

- 20" BMW i light alloy Double-spoke style 431 wheels, Bicolour with mixed tyres
- Front bumper with i3s specific High-gloss Black inlay and highlights (finished in BMW i Blue or Frozen Grey)
- High-gloss Black wheel arch extensions and wider track (+40mm)
- A-pillar and roof moulding in High-gloss Black
- i3s badge on rear tailgate
- Kidney grille, High-gloss Black with Chrome contrast edging

INTERIOR

- Front floor mat with i3s model designation in the centre

SAFETY & TECHNOLOGY

- Additional 14hp of engine power, additional 20Nm of torque and 0.4 seconds reduction in 0-62mph (0-100km/h) time
- Additional SPORT driving mode with adapted sport driving pedal behaviour
- Sport suspension (10mm lower)
- i3s-specific steering characteristics

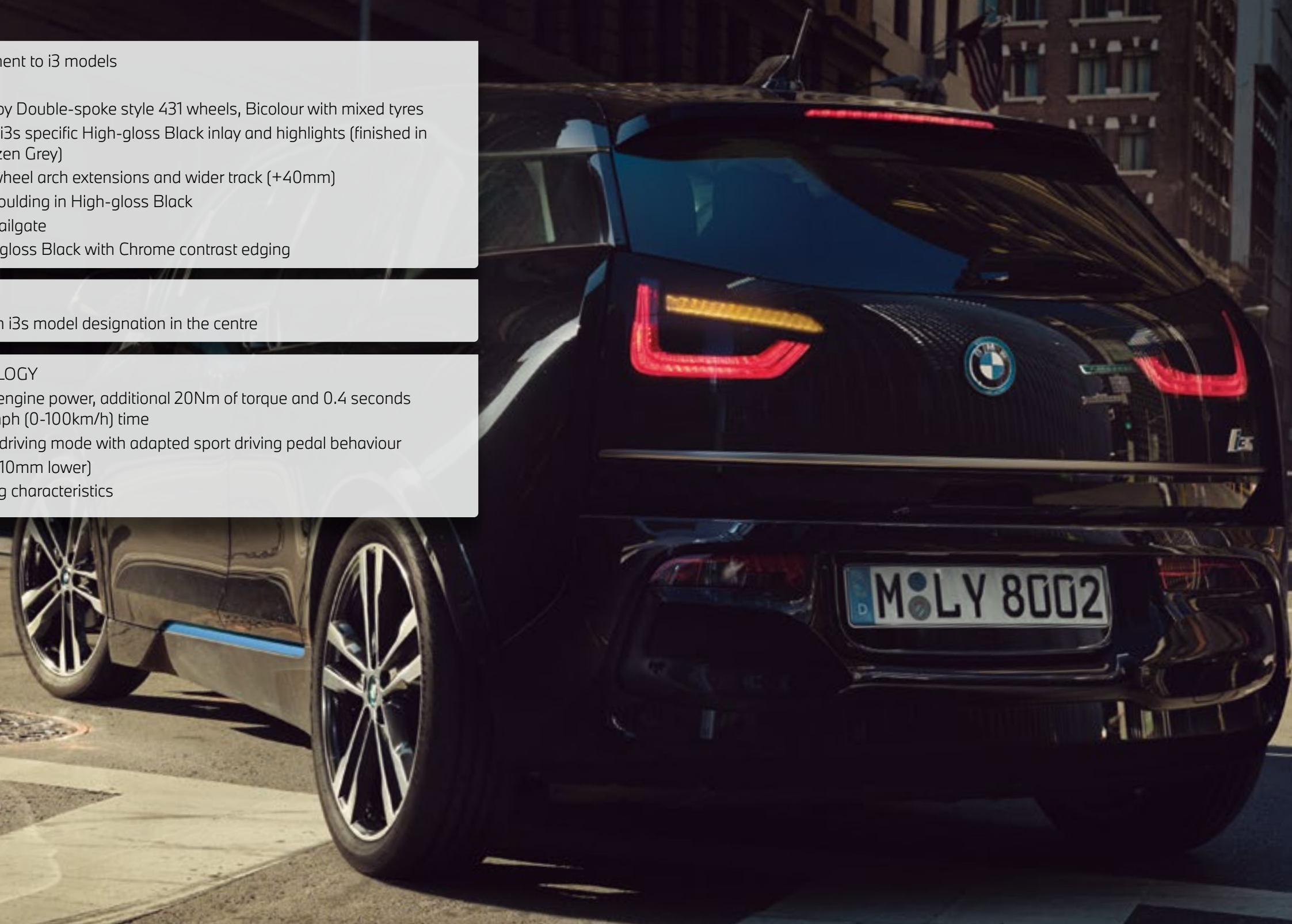

The BMW i3s 120Ah is shown above in Fluid Black non-metallic paint with BMW i Blue highlight.

■ Standard equipment □ Optional equipment

EXTERIOR COLOURS.

ALL MODELS.

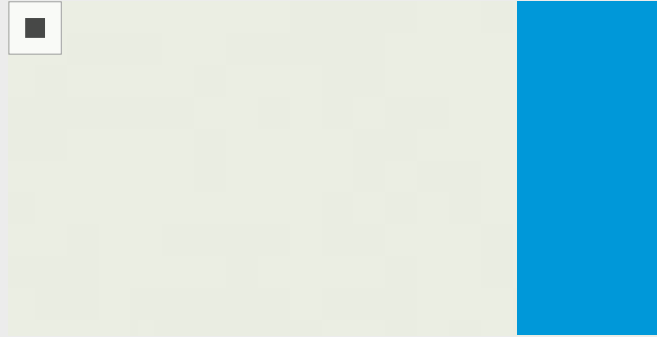

Capparis White with BMW i Blue highlight



Cashmere Silver with BMW i Blue highlight

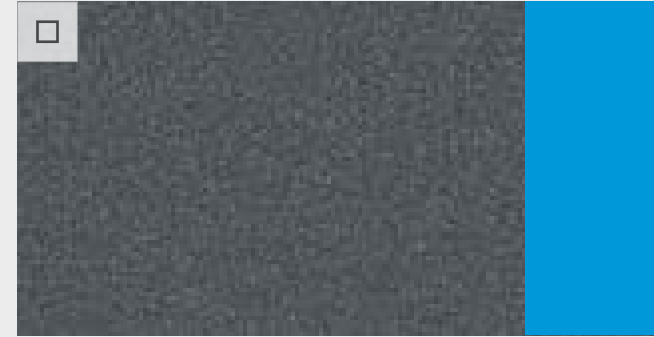

Mineral Grey with BMW i Blue highlight



Fluid Black with BMW i Blue highlight

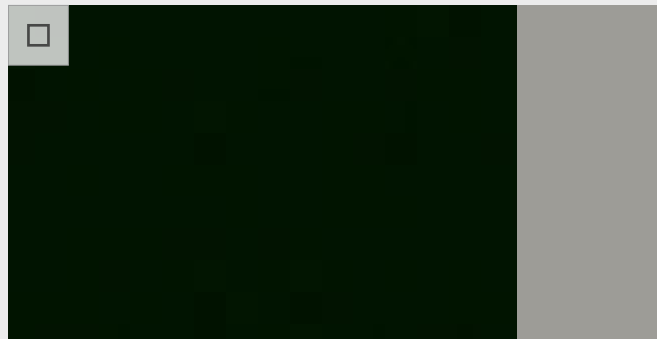

Fluid Black with Frozen Grey highlight



Imperial Blue with Frozen Grey highlight



Blue Ridge Mountain with Frozen Grey highlight



Galvanic Gold with Frozen Grey highlight

Colour samples These colour samples are intended as an initial guide to the colours and materials available for your BMW. Please discuss your preferred colour choices with your BMW Centre. There you can also see original samples and be assisted with any requests.

■ Standard equipment □ Optional equipment

INTERIOR WORLDS.

■ ATELIER.

The Atelier interior world is characterised by the gentle contrast of Dark interior trim, Grey cloth combination and individual Blue accents. The trim in the instrument panel and the door areas is made from the mallow plant kenaf. This innovative material is a particularly distinctive design feature of the standard interior world. Not only is it a lightweight material, but its subtly blended surface has the natural look of felt.



□ LOFT.

With the light Grey tones of the seats, sections of the dashboard and the side panels, the Loft interior world is characterised by an especially purist aesthetic. The modern cloth combination for the seats in both the front and rear is manufactured from recycled synthetic material, similar to that used in high-quality functional wear. This same material provides optimum comfort by means of its temperature-regulating properties.



□ LODGE.

Like no other equipment variation, the Lodge interior world embodies the new and contemporary premium concept of BMW i. The especially aesthetic combination of matt wood, soft leather and soft wool is essentially without equal in the automotive world. The Eucalyptus and Oak wood are obtained only from certified and environmentally-friendly lumber companies. The wood is neither bleached, painted nor lacquered and thus retains its surface colour and texture. The standard interior trim is Eucalyptus wood, matt. As shown below, the Dark Oak, matt is available as a no cost option.



□ SUITE.

The Suite interior world is defined by the generous use of leather in a warm, Dark Truffle colour. In the instrument panel area, it creates a stylish contrast to the contoured wooden elements made of Dark Oak. On the door panels, the leather harmonises with the individual fabric elements. Despite the vehicle's luxurious character, the BMW i designers only integrate the soft leather surfaces where the driver can feel them and therefore needs them, such as on the armrests.



OPTIONAL EQUIPMENT HIGHLIGHTS.

AUXILIARY CABIN HEATING SYSTEM.

The auxiliary heating system features an inverted air-conditioning system that draws in ambient air and heats it with a heat pump. Compared with a conventional heating system, up to 50% higher energy efficiency in heating is possible at constant heating comfort. This can improve battery range by up to approximately 30%.



ELECTRIC GLASS SUNROOF.

The electric glass sunroof features sun protection glass, tilt and slide function and an integrated wind deflector.

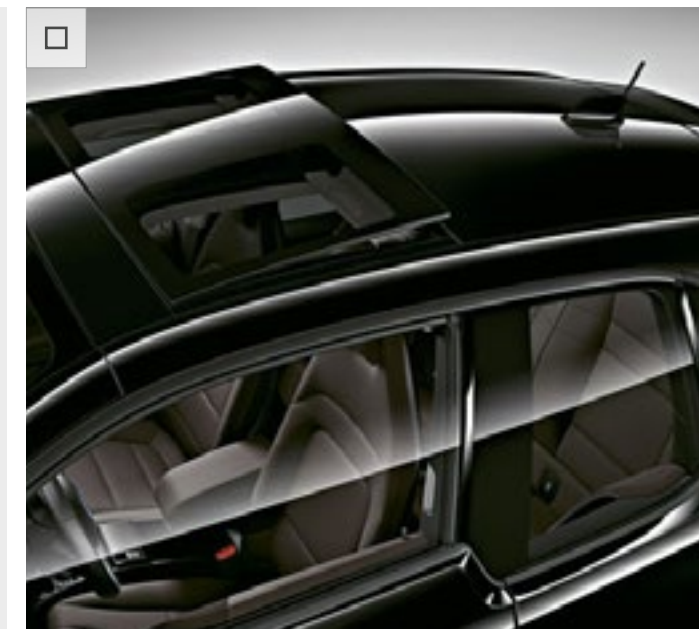

eDRIVE EXTERIOR SOUND.

The eDrive exterior sound is an artificial sound at low speeds, below approximately 20mph [32km/h]. This sound is set to be active by default when starting the vehicle but can be turned off in the iDrive system.

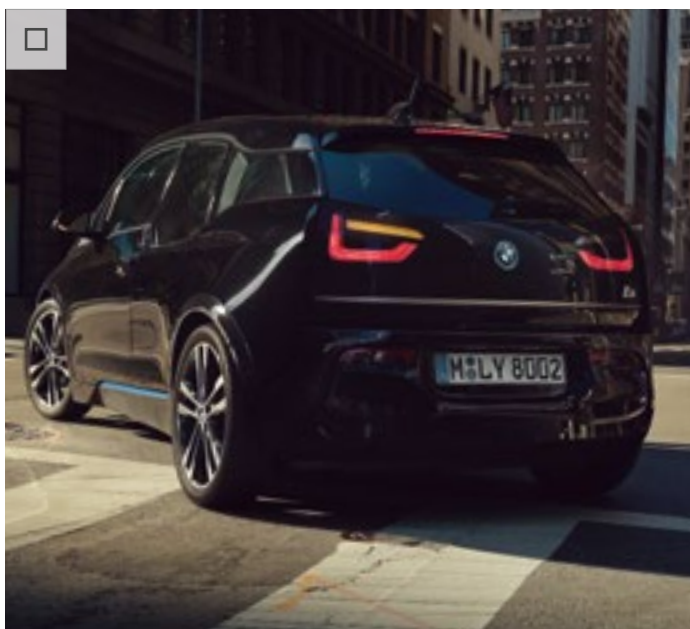

COMFORT ACCESS.

Comfort Access allows keyless access to the vehicle via both the driver and front passenger doors as well as the bootlid.

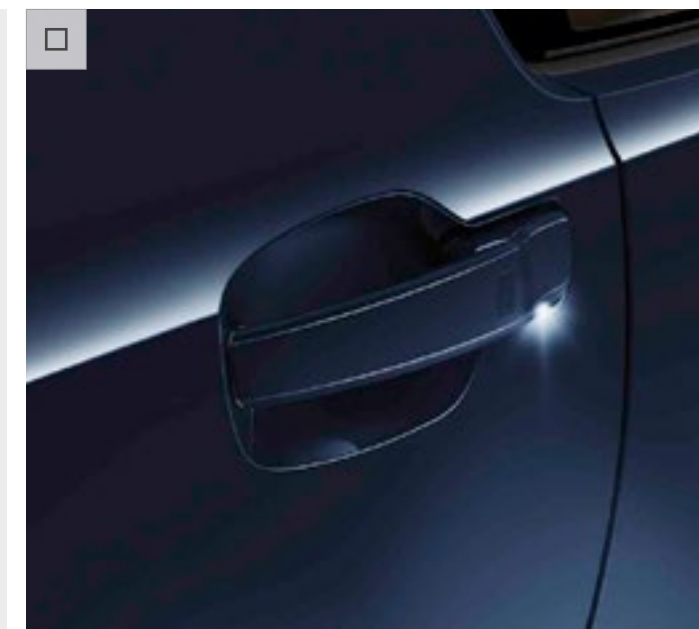

SEAT BELTS.

All four seats include seat belts in BMW i Blue. They provide the same functionality as the standard three-point seat belts.

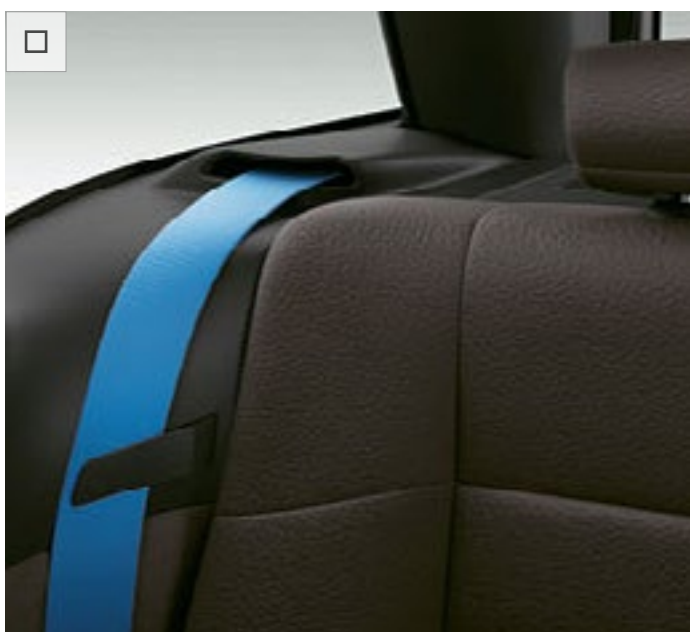

HARMAN/KARDON LOUDSPEAKER SYSTEM.

The harman/kardon loudspeaker system with surround mode has a 360W digital amplifier, vehicle-specific equalising and 12 speakers.

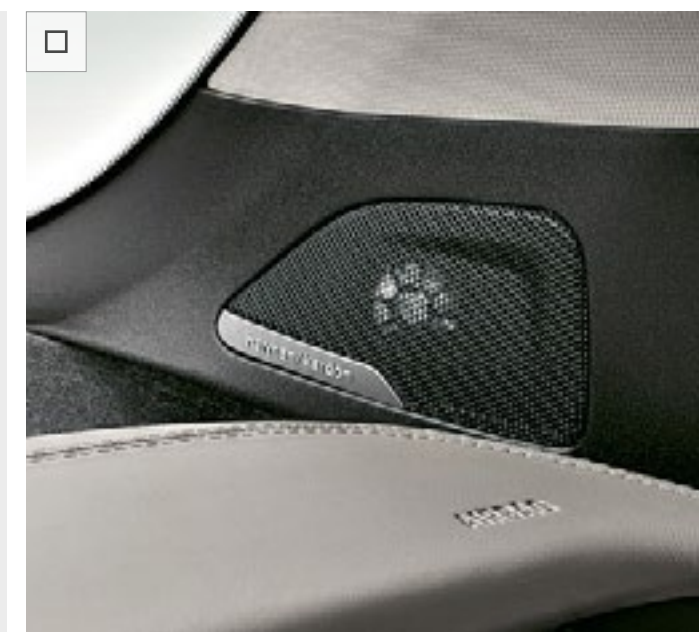

BMW CONNECTED DRIVE.

The BMW ConnectedDrive Services & Apps are on hand to make sure you have more time for the important things in life. Various innovations by BMW make things more convenient for you every day – whenever you want.

□ **Amazon Echo** gives you the ability to communicate with your vehicle using Voice Control and access your agenda from home.



□ **Door to door guidance** provides detailed walking directions from your parking spot to your destination. A map with a location pin also shows where you last parked once you're ready to head back to your car.



■ **Estimated time of arrival** provides you with detailed updates of your regular routes and alternative options so you can manage your journey and avoid delays.



■ With **Learned destinations** BMW Connected learns your most frequently travelled routes and provides them as future suggestions. If destinations are repeatedly visited, they are automatically listed at the usual time.



■ **Digital Charging Service** provides an intelligent way to charge. Simply enter your personal energy tariff, desired departure time and connect your car to an outlet or your BMW i Wallbox connect.



□ **Time to leave** function provides notifications on your Apple iPhone®, compatible Android phone, your Apple Watch® or Samsung Gear S3® watch, and recommends a time to leave to help you arrive on time.



■ **Apple CarPlay® preparation** enables wireless and comfortable usage of your iPhone® in your vehicle via Apple CarPlay®. Selected smartphone content can be displayed and operated via the user interface of the vehicle



■ **BMW Emergency Call** automatically establishes a voice connection with the local emergency services without the use of a mobile phone. It transmits information about the vehicle's current location and can be triggered manually in case other road users require help.



■ **BMW Online Services** forms the basis for using the BMW ConnectedDrive functions. In addition, selected smartphone apps can be used in the vehicle, alongside the BMW ConnectedDrive Store.



■ **Concierge Services** connects the driver to a BMW Call Centre agent who acts as their personal assistant at the touch of a button. The agent can locate a particular restaurant, for example, and send the address directly to the BMW's navigation system.



■ **Real Time Traffic Information (RTTI)** collects current traffic information about motorways, main and country roads and the most important urban routes. It relays information about delays and dangers and suggests the best alternative routes.



MY BMW APP.

The My BMW App is the direct connection inside and outside your BMW. Plan your next trip, check the status of your vehicle or use one of the remote service functions – all conveniently from your smartphone.

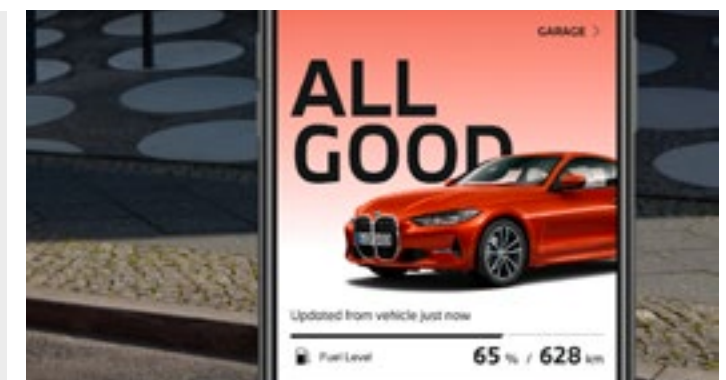

CHARGING.

Soon after purchasing an electric car, you'll find that charging becomes more of an intuitive routine than a specific operation. Thanks to the portfolio of 360° ELECTRIC Products and Services, which provide easy and convenient charging, you can always rely on your BMW i3.

Using the cable provided, you can charge the high voltage battery via a conventional¹ socket. However, for regular fast charging BMW recommends the BMW i Wallbox for a convenient home solution. With the BMW i Wallbox Connect, AC fast charging can take less than 5 hours (0-80%). For rapid charging, the standard DC rapid-charge function is the perfect solution for the BMW i3. Charging up at a suitable public charging point, for example, a DC rapid-charge facility takes approximately 42 minutes (0-80%).

For more information please visit www.bmw.co.uk/charging



	Standard charge	AC Fast charge	AC Rapid Charge	DC Rapid charge
Specification	AC Type 2 / Mode 2 Charging / up to 2.3kW / 10Amps	AC Type 2 / Mode 3 Charging / 7.4kW / 32Amps	AC Type 2 / Mode 3 Charging / 11kW / 3 x 16Amps	DC Combo 2 / Mode 4 Charging / 50kW
Approximate Charging time	< 15 hours for 0-80% State of Charge	< 4.9 hours for 0-80% State of Charge	< 3.2 hours for 0-80% State of Charge	< 42 minutes for 0-80% State of Charge

The design of the charging cable may vary from images shown. ¹ = It is advised that domestic electrical wiring is checked by a qualified electrician.

HOME CHARGING.

FOR FAST AND SAFE CHARGING AT HOME.

The progressive and ergonomically designed BMW i Wallbox Connect fulfils the important requirements of safety and comfort making it the ideal home charging solution. With the standard charging cable, you can charge your BMW i3 from 0-80% at home via a conventional socket¹ in around fifteen hours. However, charging at home is made even easier with the BMW i Wallbox Connect. With a charging capacity of up to 11kW the lithium-ion high-voltage battery in the BMW i3 and BMW i3s is charged 0-80% in around 3.2 hours².

The ergonomic, high-quality design of the BMW i Wallbox Connect provides maximum charging convenience with the ability to wrap the cable around the Wallbox. The BMW i Wallbox Connect also features RFID chip card authentication for secured charging of up to three different vehicles. For even greater convenience, the BMW i Wallbox Connect is WiFi enabled for simple integration to your home network[^] and can be controlled via the BMW iV smartphone app (iOS, Android), where session energy consumption can be viewed. Furthermore, 'Intelligent Charging' is possible in connection with the additional Digital Charging Service available from BMW.

Collectively these are all aspects that have a positive impact on cost and ultimately ensures a sustainable charging experience.

A delivery, fitting and warranty package for the BMW i Wallbox Connect is also offered via our partner, BP Chargemaster.

Starting from £975* this includes the BMW i Wallbox Connect, Standard Installation, VAT and three year warranty.

During the installation process, the service team will be able to advise on any questions you may have regarding how to charge and use your BMW i Wallbox Connect, and where best to position it in relation to where you park your BMW i3. The installation service is managed by BMW and our partner, BP Chargemaster, and is customised to your specific requirements.

For responsible charging, the BMW i3 comes with a seven day timer to aid charging at night, when renewable energy makes a higher proportion of the energy supply and when demand is at its lowest.

For more information please visit www.bmw.co.uk/charging



BMW i Wallbox Connect



¹ = It is advised that domestic electrical wiring is checked by a qualified electrician. ² = Dependent on local electricity infrastructure and the selected optional equipment. [^] = Compatibility and survey dependent, additional costs may apply.
* = Subject to OLEV subsidy and qualification which may be liable to change. The design of the charging cable may vary from images shown.

PUBLIC CHARGING.

ChargeNow is a service from BMW i which, in partnership with BP Chargemaster, enables customers in the UK to access the largest network of public charging points nationwide with a single card – the BMW i ChargeNow charging card. Charging points in the ChargeNow network are displayed using the BMW i ConnectedDrive Services in the specially developed navigation system, making it especially quick and easy to find and use public charging points in conjunction with the BMW i Public Charging cable supplied with the vehicle.

Furthermore, their availability[†] is displayed in real time, indicating whether the points are available for use.

For a monthly fee of £7.85 and pay-as-you-charge access, payment is simple and cashless via the ChargeNow card. You will also receive a detailed itemised statement once a month and can access your account information online.

For more information please visit www.bmw.co.uk/charging



BMW i Public Charging Cable



ChargeNow card



The design of the charging cable may vary from images shown. [†] = Applies to ChargeNow Partner charging points only.

ASSISTANCE SERVICES.

ASSISTANCE SERVICES.

BMW's portfolio of assistance services offers a broad range of solutions for all daily challenges that customers face. For BMW i drivers, the range of services for BMW vehicles has been complemented with specific eMobility services to make running an electric vehicle simple.

BMW ConnectedDrive applications assist you with charging as well as using your BMW i vehicle. Your BMW i3 will, for example, notify you via your Smartphone application about the current charging

status, inform you about the battery State of Charge or remind you if the vehicle needs to be recharged to maintain the battery. And of course BMW i Mobile Care will support you 24 hours a day, 7 days a week in case there is an unforeseen event.

Your BMW i3 also comes with an eight year / 100,000 mile high voltage battery warranty as standard, to accompany the three year unlimited mileage vehicle warranty.

BMW i MOBILE CARE.

With the purchase of a BMW i3 and i3s, the comprehensive BMW i Mobile Care package is automatically provided. This ensures that professional help is available via telephone for any unforeseen events that could affect the vehicle or charging infrastructure and, if needed, provides rapid assistance at your location. In the event of an emergency,

assistance is available 24 hours a day, wherever you are in the UK, and help is on hand to either recover your vehicle to the most appropriate BMW Centre or to find the most practical way to recharge it. In the unfortunate event of your vehicle being off the road, we provide a two-day car hire period so that you can remain mobile, minimising any inconvenience*.



SERVICE INCLUSIVE.

BMW i Service Inclusive: BMW i wants to keep servicing costs simple and transparent to you. That is exactly why our BMW i Service Inclusive Packages have been tailored to the requirements of your BMW i3. See [BMW Pay Monthly Servicing & Trackstar](#) for pricing information.

* = Mobility will result in the loan of a vehicle and like for like replacements are not applicable as part of the BMW i Mobile Care terms.

WHEELS & TYRES.

20" BMW i LIGHT ALLOY DOUBLE-SPOKE STYLE 431 WHEELS, JET BLACK.

20" BMW i light alloy Double-spoke style 431 wheels, Jet Black, front 5.5J x 20 with 175/55 R20 tyres, rear 6J x 20 with 195/50 R20 tyres.

Optional for BMW i3s.

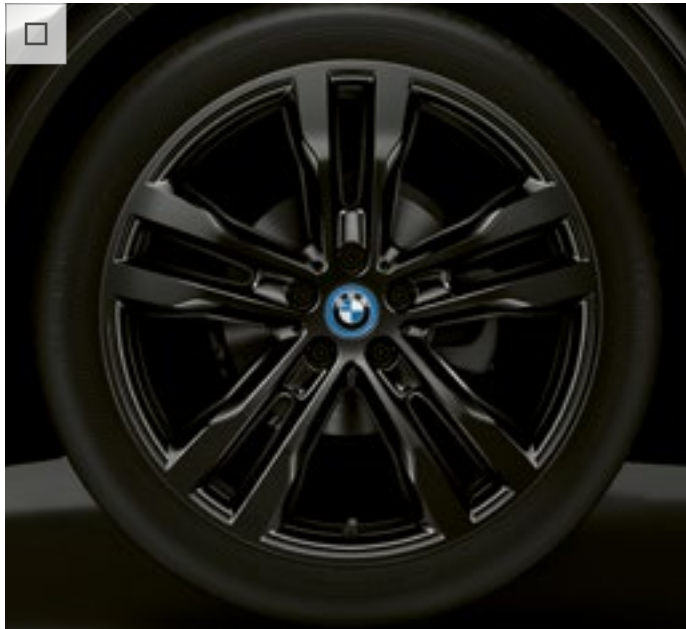

20" BMW i LIGHT ALLOY DOUBLE-SPOKE STYLE 431 WHEELS.

20" BMW i light alloy Double-spoke style 431 wheels, front 5.5J x 20 with 175/55 R20 tyres, rear 6J x 20 with 195/50 R20 tyres.

Standard for BMW i3s.



20" BMW i LIGHT ALLOY DOUBLE-SPOKE STYLE 430 WHEELS, BICOLOUR.

20" BMW i light alloy Double-spoke style 430 wheels, Bicolour, front 5J x 20 with 155/60 R20 tyres, rear 5.5J x 20 with 175/55 R20 tyres.

Optional for BMW i3.



19" BMW i LIGHT ALLOY TURBINE STYLE 428 WHEELS, BICOLOUR.

19" BMW i light alloy Turbine style 428 wheels, Bicolour, front 5J x 19 with 155/70 R19 tyres, rear 5.5J x 19 175/60 R19 tyres.

Optional for BMW i3.



19" BMW i LIGHT ALLOY TURBINE STYLE 429 WHEELS, BICOLOUR.

19" BMW i light alloy Turbine style 429 wheels, Bicolour, front 5J x 19 with 155/70 R19 tyres, rear 5.5J x 19 with 175/60 R19 tyres.

Standard for BMW i3.



19" BMW i LIGHT ALLOY STREAMLINE STAR-SPOKE STYLE 427 WHEELS.

19" BMW i light alloy Streamline Star-spoke style 427 wheels, 5J x 19 with 155/70 R19 tyres.

Optional for BMW i3.



GENUINE BMW i ACCESSORIES.

A BMW i3 always delivers a special drive and Genuine BMW i Accessories make the experience better still. Combining great ideas, immaculate design and sheer practicality to create innovative solutions, Genuine BMW i Accessories are available in many categories: exterior, interior, communications & information and transport & luggage compartment solutions. Your BMW Centre will be pleased to advise you on the complete range of Genuine BMW i Accessories. For further information, please visit www.bmw.co.uk/accessories



The design of the charging cable may vary from images shown.

© Accessories

PRICING INFORMATION.



i3 120Ah	i3s 120Ah
----------	-----------

Basic price (excluding VAT)	£29,266.67	£31,375.00
VAT 20%	£5,853.33	£6,275.00
RRP (including VAT)	£35,120	£37,650
On the road price from	£36,025	£38,555
On the road price (including grant [^])	£33,025	£35,555
P11d value – Automatic	£35,970	£38,500
BIK tax rate (2020 / 2021)	0%	0%
Insurance group	28	29
RDE2 Compliant (Y / N)	N	N

PRICES AND SPECIFICATIONS

BMW (UK) Limited reserves the right to alter prices and specifications without notice. BMW (UK) Limited has made every effort to ensure the accuracy of information but does not accept liability for any errors or omissions.

VED RATES

Annual VED (second year onwards), for cars costing over £40,000, is payable for five years. VED rates for brand cars are determined by their CO₂ emissions figure. First year VED applies to the first year of ownership. Annual VED rates apply thereafter. The BMW i3 and i3s 120Ah fall into the category below:

CO ₂ emissions – combined (g/km)	0
First year VED	£0
Annual VED – second year onwards (standard rate for electric vehicles)	£0
Annual VED – second year onwards (electric vehicles over £40,000)	£325

These figures were obtained after the battery had been fully charged. The BMW i3 and i3s 120Ah is a battery electric vehicle requiring mains electricity for charging. There is a new test for fuel consumption, CO₂ and electric range figures. The electric range shown was achieved using the new test procedure. Figures shown are for comparability purposes. Only compare fuel consumption, CO₂ and electric range figures with other cars tested to the same technical procedures. These figures may not reflect real life driving results, which will depend upon a number of factors including the starting charge of the battery, accessories fitted (post-registration), variations in weather, driving styles and vehicle load. The CO₂ figures shown above have been determined according to the WLTP test. WLTP has been used as the applicable CO₂ figure from 1 April 2020 for first year vehicle tax (VED) and from 6 April 2020 for company car tax (BIK). The CO₂ figures were previously based on the NEDC equivalent. [^] = The price shown includes the HM Government Plug-In Car Grant of up to a maximum of £3,000 (applied the full price of the basic vehicle including number plates, vehicle excise duty, and VAT). The receipt of this grant is subject to the eligibility of the vehicle for the Plug-In Car Grant scheme at the point of the vehicle's first registration in the UK. The grant amount and vehicle eligibility may change from time to time following Government policy or regulation. Insurance group figures refer to 50 Group Rating System.



To find out more about the benefits of owning an ultra low emission vehicle, including the Government's grants for vehicles and chargepoints, visit www.GoUltraLow.com

ON THE ROAD PRICE

The recommended on the road price includes:

Delivery and BMW Emergency Service	£825
Number plates	£25
Vehicle first registration fee	£55
First year Vehicle Excise Duty	See left

TECHNICAL INFORMATION.



	i3 120Ah	i3s 120Ah
--	----------	-----------

	i3 120Ah	i3s 120Ah
Power output (hp)	170	184
0-62mph / 0-100km/h (secs)	7.3	6.9
Fuel consumption – combined (mpg / l/100km)*	n/a	n/a
CO ₂ emissions – combined (g/km)*	0	0
Electric energy consumption – weighted combined (miles/kWh)*	3.9-4.1	3.8
Electric energy consumption – weighted combined (km/kWh)*	11.5-11.1	11.5-11.1
Pure Electric Range – combined (miles)*	182.1-190.8	173.4-175.2
Pure Electric Range – combined (km)*	293.0-307.0	279.0-282.0

* = These figures were obtained after the battery had been fully charged. The BMW i3 and i3s 120Ah is a battery electric vehicle requiring mains electricity for charging. There is a new test for fuel consumption, CO₂ and electric range figures. The electric range shown was achieved using the new test procedure. Figures shown are for comparability purposes. Only compare fuel consumption, CO₂ and electric range figures with other cars tested to the same technical procedures. These figures may not reflect real life driving results, which will depend upon a number of factors including the starting charge of the battery, accessories fitted (post-registration), variations in weather, driving styles and vehicle load. The CO₂ figures shown above have been determined according to the WLTP test. WLTP has been used as the applicable CO₂ figure from 1 April 2020 for first year vehicle tax (VED) and from 6 April 2020 for company car tax (BIK). The CO₂ figures were previously based on the NEDC equivalent.

OPTIONAL EQUIPMENT PRICING.



	i3 120Ah	i3s 120Ah	Price
--	----------	-----------	-------

PAINTWORK

Non-metallic Available in Capparis White with BMW i Blue highlight	■	■	Std
Non-metallic Available in Fluid Black with BMW i Blue highlight ¹ or Fluid Black with Frozen Grey highlight ²	□	□	£550
Metallic Available in Blue Ridge Mountain with Frozen Grey highlight, Cashmere Silver with BMW i Blue highlight, Galvanic Gold with Frozen Grey highlight, Imperial Blue with Frozen Grey highlight or Mineral Grey with BMW i Blue highlight	□	□	£550

UPHOLSTERY

Neutronic cloth Available in Aragats Grey / Black Only with and included in Interior world, Atelier	■	■	Std
Electronic cloth / Sensatec synthetic leather Available in Carum Spice Grey / Brown Only with and included in Interior world, Loft	□	□	n/a
Solaric wool cloth / natural leather Available in Brown / Carum Spice Grey Only with and included in Interior world, Lodge	□	□	n/a
Vernasca leather / cloth Available in Dark Truffle / Carbon Black Only with and included in Interior world, Suite	□	□	n/a

BMW EFFICIENT DYNAMICS

Brake Energy Regeneration	■	■	Std
ECO PRO mode	■	■	Std
ECO PRO+ mode	■	■	Std
Electric Power Steering (EPS)	■	■	Std
Lightweight engineering featuring Carbon fibre reinforced plastic (CFRP) body structure	■	■	Std
Lightweight alloy wheels with unique streamline design	■	■	Std
Reduced Rolling Resistance Tyres	■	■	Std

Individual BMW EfficientDynamics features may be excluded, depending on the optional equipment chosen. Your BMW Centre will be pleased to provide you with more information.

Only with = these options must be ordered together. ¹ = All exterior parts finished in Fluid Black or Black except the BMW i Blue highlight. ² = All exterior parts finished in Fluid Black or Black except the Frozen Grey highlight.

■ Standard equipment □ Optional equipment - Not available



	i3 120Ah	i3s 120Ah	Price
--	----------	-----------	-------

PACKAGES

i3 PLUS PACKAGE Comprising: – 20" BMW i light alloy Double-spoke style 430 wheels, Bicolour with mixed tyres – Loudspeaker system – harman/kardon – Online Entertainment – Sun protection glass	□	-	£1,400
i3S PLUS PACKAGE Comprising: – 20" BMW i light alloy Double-spoke style 431 wheels, Jet Black with mixed tyres or 20" BMW i light alloy Double-spoke style 431 with mixed tyres – Loudspeaker system – harman/kardon – Online Entertainment – Sun protection glass	-	□	£1,100
PARK ASSIST PACKAGE Comprising: – Park Assist – Park Distance Control (PDC), front and rear – Reversing Assist camera	□	-	£790



i3 120Ah	i3s 120Ah	Price
----------	-----------	-------

INTERIOR WORLDS

<p>Atelier</p> <p>Comprises:</p> <ul style="list-style-type: none"> – Front interior light in White colour with LED soft-light – Interior trim, Andesit Silver, matt¹ – Multi-function steering wheel, Black with contrast BMW i Blue accent – Neutronic cloth in Aragats Grey with BMW i Blue highlight – Velour floor mats, Anthracite 	■	■	Std
<p>Loft</p> <p>Comprises:</p> <ul style="list-style-type: none"> – Electronic cloth / Sensatec synthetic leather upholstery, Carum Grey / Brown – Extended lighting – Interior trim, Electronic Brown¹ – Multi-function steering wheel, Carum Spice Grey with BMW i Blue accent – Velour floor mats, Anthracite 	□	□	£1,000
<p>Lodge</p> <p>Comprises:</p> <ul style="list-style-type: none"> – Extended lighting – Interior trim, Eucalyptus wood, matt¹ – Instrument panel, Carum Spice Grey – Multi-function steering wheel, Carum Spice Grey with Satin Silver accent – Solaric Climate Active wool / leather upholstery, Grey / Brown – Velour floor mats, Anthracite 	□	□	£1,500
<p>Suite</p> <p>Comprises:</p> <ul style="list-style-type: none"> – Extended lighting – Instrument panel, Dark Truffle Vernasca leather – Interior trim, Dark Oak, matt¹ – Multi-function steering wheel, Black with contrast Satin Silver accent – Velour floor mats, Anthracite – Vernasca leather upholstery, Dark Truffle 	□	□	£2,000

¹ = Other Interior Trims available at an additional cost.



	i3 120Ah	i3s 120Ah	Price
--	----------	-----------	-------

INTERIOR TRIMS

Andesit Silver, matt Only with Interior world, Atelier	■	■	Std
Dark Oak wood, matt With Interior worlds, Atelier / Loft	□	□	£350
With Interior world, Lodge	□	□	£0
With Interior world, Suite	■	■	Std
Electronic Brown Only with Interior world, Loft	□	□	n/a
Eucalyptus wood, matt With Interior worlds, Atelier / Loft	□	□	£350
With Interior world, Lodge	■	■	Std
With Interior world, Suite	□	□	£0

SAFETY & TECHNOLOGY

BMW Icon Adaptive LED Headlights Only with High-beam Assistant + Driving Assistant Plus	□	□	£790
eDrive exterior sound	□	□	£80
Driving Assistant Plus Comprises: – Active Cruise Control with Stop&Go – City Collision Mitigation – Forward Collision Warning – Preventive Pedestrian Protection – Speed Limit Display – Traffic Jam Assist	□	□	£790
High-beam Assistant Only with BMW Icon Adaptive LED Headlights + Driving Assistant Plus	□	□	£0
Park Distance Control (PDC) front and rear Only with and included in Park Assist Package (i3 models)	□	-	n/a
	-	□	£170
Reversing Assist camera Only with and included in Park Assist Package (i3 models)	□	-	n/a
	-	□	£360

SEATS

Seat belts, BMW i Blue	□	□	£125
------------------------	---	---	------

Only with = these options must be ordered together.

■ Standard equipment □ Optional equipment - Not available



	i3 120Ah	i3s 120Ah	Price
--	----------	-----------	-------

EXTERIOR EQUIPMENT

Comfort Access	<input type="checkbox"/>	<input type="checkbox"/>	£330
----------------	--------------------------	--------------------------	------

INTERIOR EQUIPMENT

Auxiliary cabin heating system Comprising: – Heat pump	<input type="checkbox"/>	<input type="checkbox"/>	£530
Electric glass sunroof ¹	<input type="checkbox"/>	<input type="checkbox"/>	£780
Smoker's package	<input type="checkbox"/>	<input type="checkbox"/>	£20
Sun protection glass Included in i3 Plus Package / i3s Plus Package	<input type="checkbox"/>	<input type="checkbox"/>	£280

AUDIO & COMMUNICATION

Apple CarPlay [®] preparation ^{2,3,4}	<input checked="" type="checkbox"/>	<input checked="" type="checkbox"/>	Std
BMW Emergency Call ⁵	<input checked="" type="checkbox"/>	<input checked="" type="checkbox"/>	Std
BMW Online Services ^{2,5}	<input checked="" type="checkbox"/>	<input checked="" type="checkbox"/>	Std
BMW TeleServices ⁴	<input checked="" type="checkbox"/>	<input checked="" type="checkbox"/>	Std
Concierge Services ^{2,5}	<input type="checkbox"/>	<input type="checkbox"/>	£240
Connected eDrive Services ⁶	<input checked="" type="checkbox"/>	<input checked="" type="checkbox"/>	Std
DAB digital radio	<input checked="" type="checkbox"/>	<input checked="" type="checkbox"/>	Std
Enhanced Bluetooth with wireless charging Only with WiFi hotspot preparation	<input type="checkbox"/>	<input type="checkbox"/>	£395
Loudspeaker system – harman/kardon Included in i3 Plus Package / i3s Plus Package	<input type="checkbox"/>	<input type="checkbox"/>	£640
Navigation system – BMW Professional Multimedia	<input checked="" type="checkbox"/>	<input checked="" type="checkbox"/>	Std
Online Entertainment ^{2,7} Included in i3 Plus Package / i3s Plus Package	<input type="checkbox"/>	<input type="checkbox"/>	£160
Real Time Traffic Information ^{2,5}	<input checked="" type="checkbox"/>	<input checked="" type="checkbox"/>	Std
WiFi hotspot preparation ⁸ Only with Enhanced Bluetooth with wireless charging	<input type="checkbox"/>	<input type="checkbox"/>	£0







Only with = these options must be ordered together. / = Indicates 'or' ¹ = When specifying this option the roof panel at the rear is changed from CFRP (Carbon-fibre reinforced plastic) to Aluminium painted Black. The front remains the same with the glass panel sunroof. ² = Requires a free BMW ConnectedDrive account. ³ = Compatibility and functions may vary due to the model year of the iPhone[®] and the version of software installed on it. Functions using a data connection will use data from the SIM card in the iPhone[®]. Additional data charges may be applied by the mobile network provider. ⁴ = Available and active without runtime limitations. Usage cannot be guaranteed permanently due to potential future technical developments (of the Service availability and/or Smartphone compatibility/operating systems). ⁵ = Active for 3 years, renewable thereafter. ⁶ = Includes three year subscription to BMW Digital Charging Service. ⁷ = Includes subscription to a chosen music partner for one year. ⁸ = Data subscription costs apply and must be purchased separately.

■ Standard equipment □ Optional equipment - Not available

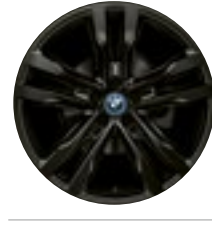

i3 120Ah	i3s 120Ah	Price
----------	-----------	-------

LIGHT ALLOY WHEELS

	19" BMW i Streamline Star-spoke style 427	□	-	£0
	19" BMW i Turbine style 428, Bicolour	□	-	£150
	19" BMW i Turbine style 429, Bicolour	■	-	Std
	20" BMW i Double-spoke style 430, Bicolour Included in i3 Plus Package	□	-	£600
	20" BMW i Double-spoke style 431, Jet Black Included in i3s Plus Package	-	□	£150
	20" BMW i Double-spoke style 431	-	■	Std

See [Wheels & Tyres](#) for further details.

■ Standard equipment □ Optional equipment - Not available

	i3 120Ah	i3s 120Ah	Price
---	----------	-----------	-------

360° ELECTRIC

Digital Charging Service – 36 months subscription ¹	■	■	n/a
Home charging: BMW i Wallbox Connect (32 Amp) with Standard Installation ²	□	□	From £975+
Public Charging: BMW i AC Rapid Charge Cable (5 metre length) – Max 32 Amp 3-phase public charging cable, Type 2 connectors	■	■	n/a
Public Charging: BMW i AC Fast Charge Cable (8 metre length) – Max 32 Amp 1-phase public charging cable, Type 2 connectors	□	□	£195
Public charging: ChargeNow – Pay as you go charging ³	□	□	£7.85 per month
Assistance Services – BMW i Mobile Care – Battery Warranty – Vehicle Warranty	■	■	n/a



+ = Subject to OLEV subsidy and qualification which may be liable to change, for further details please speak to your local BMW Centre. For more information about Battery Electric Vehicles please visit <https://www.bmw.co.uk/en/topics/discover/electric-and-phev/electric-cars.html> ¹ = 36 months subscription from production date only, renewable thereafter for £45 per annum via the ConnectedDrive Store.. ² = Includes 3 year warranty. ³ = Available as a stand alone service. Terms and Conditions apply, find out more at www.chargenow.com

DIMENSIONS.

THE BMW i3 & i3s.

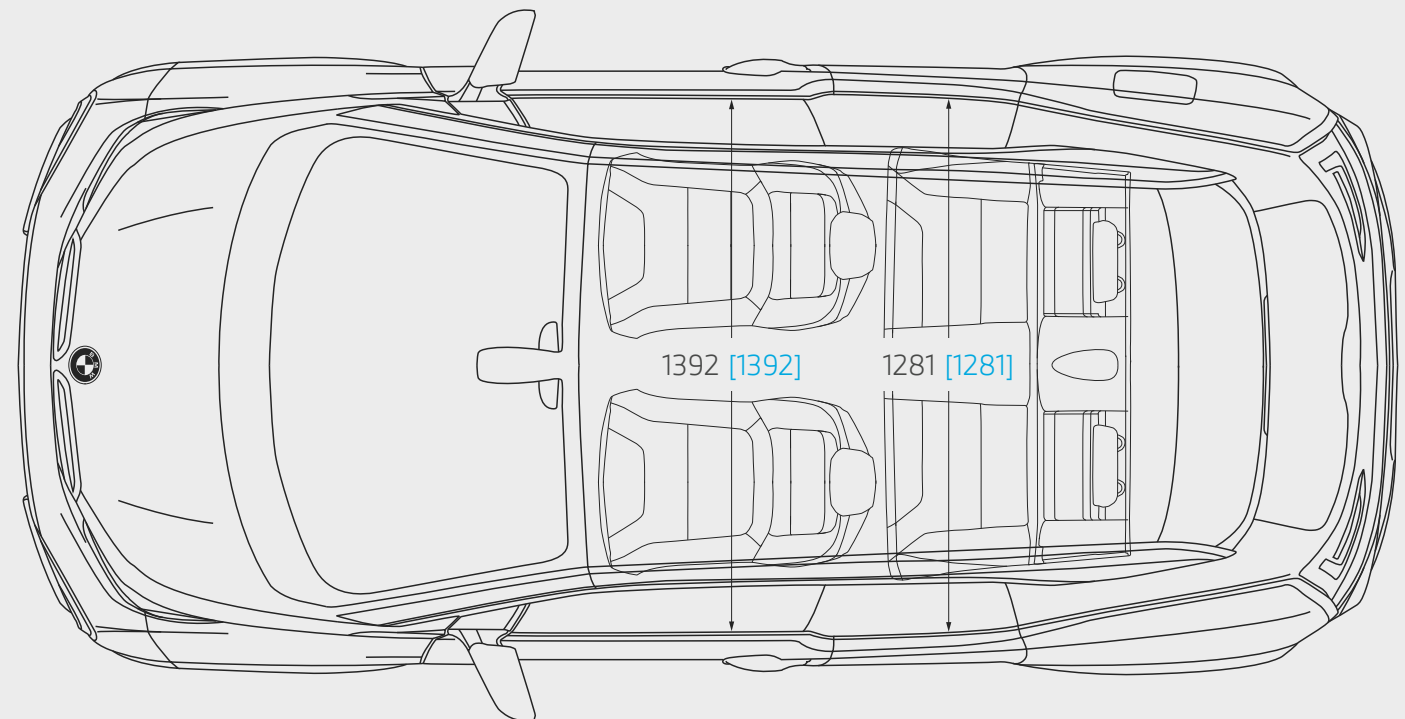
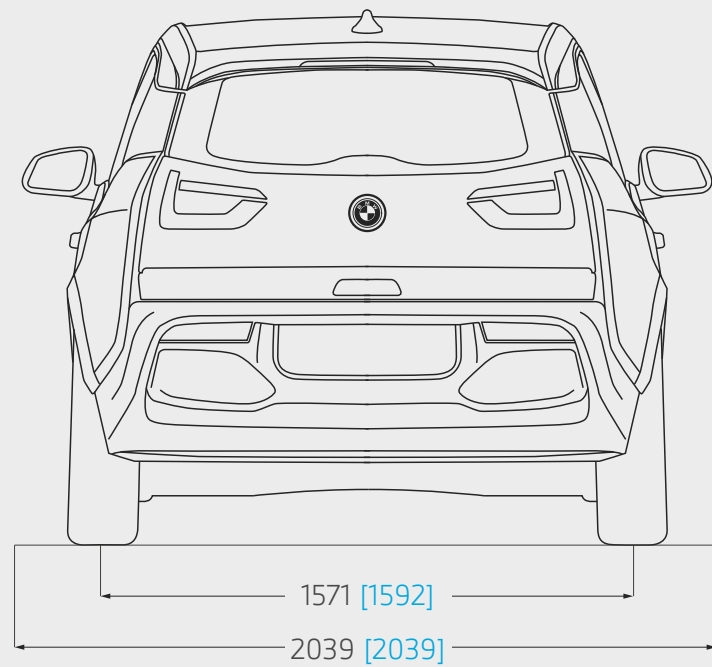
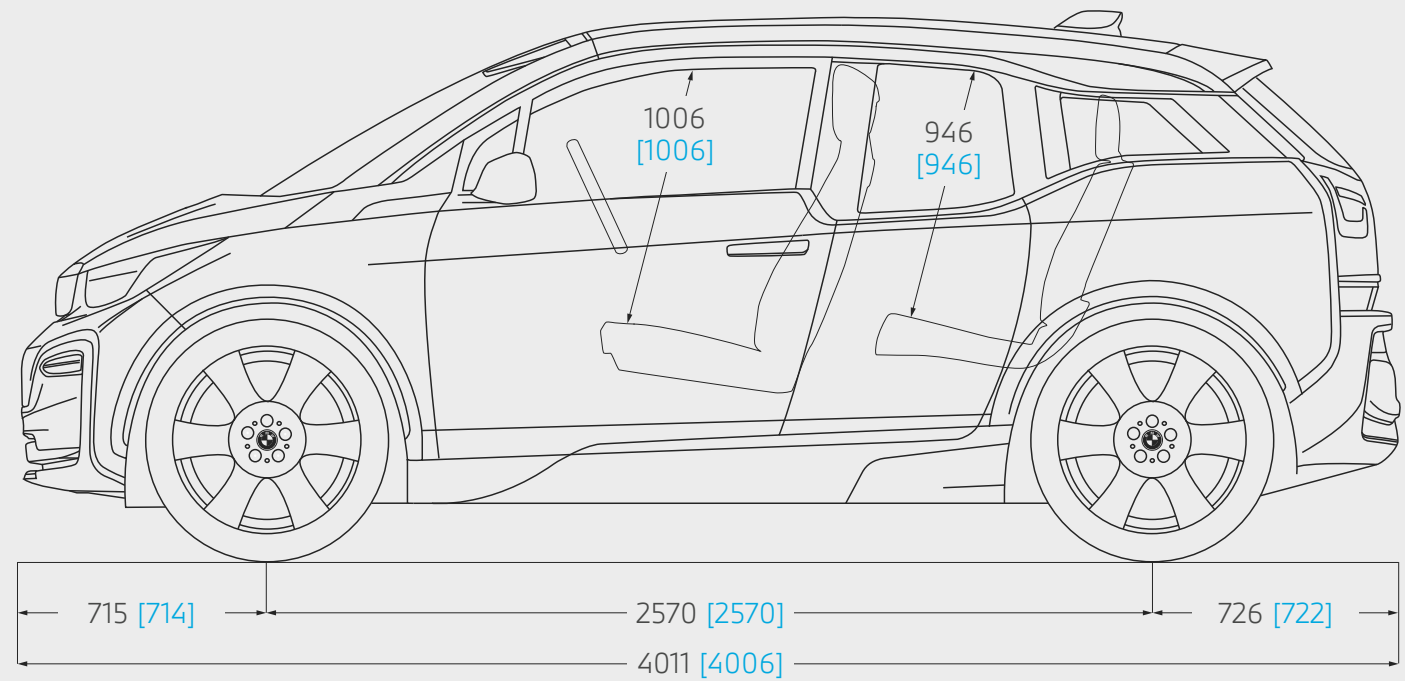
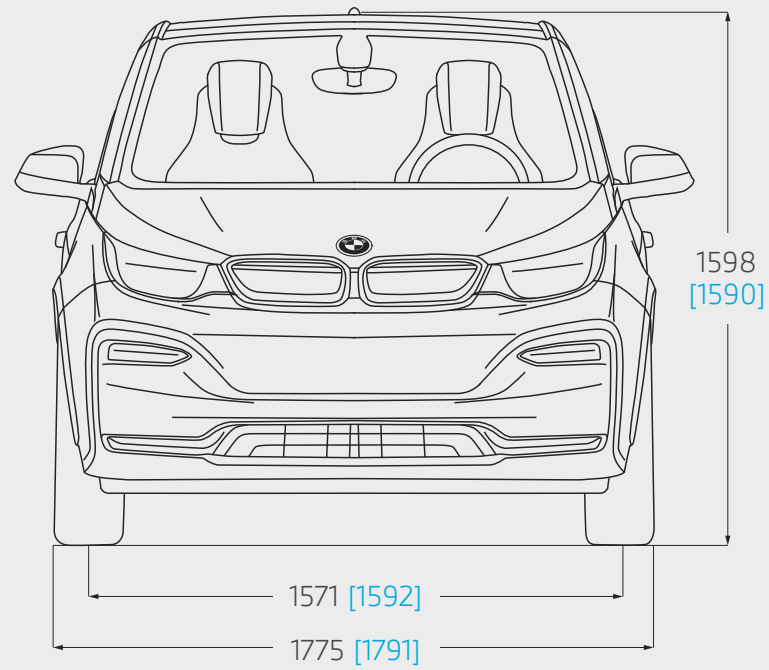

Length (mm)	4011 [4006]	Height (mm)	1598 [1590]	Number of seats	4 [4]	Turning circle (m)	9.9 [10.3]
Width (mm)	1775 [1791]	Width including mirrors (mm) (Driver / Passenger)	2039 [1031 / 1008] [2039 [1031 / 1008]]	Wheelbase (mm)	2570 [2570]	Luggage capacity (litre)	260-1100 [260-1100]

Figures in [] apply to the BMW i3s.

BMW PAY MONTHLY SERVICING & TRACKSTAR.

SERVICING MADE SIMPLE.

Planning for the road ahead has never been easier. With the BMW Pay Monthly Service Plan¹ you can remove the uncertainty often associated with car servicing costs by spreading them monthly, much like you would your household bills. Our Pay Monthly service plan covers two services and any unused credit can be transferred to another BMW if you decide to switch unexpectedly. As part of the Pay Monthly plan you will also receive a number of added extras including:

- Fluid top ups
- An MOT
- A Wash & Vac each time you visit
- Seasonal health checks
- Sat Nav Map updates

Get the quality service and parts you expect from BMW with a fixed monthly payment. Give your BMW the care and attention it deserves from the experts that made it.

Price: £15 per month for 36 months

Please contact your preferred BMW Centre for further information.

BMW TRACKSTAR.

Locate and recover your vehicle if it is stolen with BMW Trackstar or BMW Trackstar Advance. Benefits include:

- 24/7 Trackstar Monitoring Centre
- Thatcham accredited
- Integrated motion sensor
- Pan-European protection

BMW Trackstar S7 price from: £399²

BMW Trackstar S5 price from £549²

BMW Trackstar S5 Advance price from: £649²



¹ = Participating BMW Centres only. Two services must be claimed within four years or 40,000 miles, whichever occurs soonest. ² = Price excludes subscription. Please consult your preferred BMW Centre for further details. Content correct at time of publishing. Prices subject to change.

BMW CONNECTED DRIVE SERVICES.

BMW ConnectedDrive keeps driver and vehicle connected with the outside world. Digital services, driver-focused technologies and driver assistance systems provide more comfort, more entertainment and more safety. Increase your driving pleasure – with BMW ConnectedDrive.

For further information on BMW ConnectedDrive and the General Terms and Conditions of Service for ConnectedDrive, please see: www.bmw.co.uk/connecteddrive-information

The BMW ConnectedDrive Hotline is available on: +44 (0) 800 561 0555 from Monday to Friday 8am – 7pm and Saturday to Sunday 9am – 5pm.

CONNECTED DRIVE SERVICES DURATION

Online Entertainment	1 year
BMW Online Services	3 years
Concierge Services	3 years
Connected eDrive Services	3 years
Real Time Traffic Information	3 years
Apple CarPlay® preparation	Available and active without runtime limitations.
BMW Emergency Call	Available and active without runtime limitations.
BMW TeleServices	Available and active without runtime limitations.
Remote Services	Available and active without runtime limitations.

GENERAL INFORMATION

BMW (UK) Ltd, Summit ONE, Summit Avenue, Farnborough, Hampshire, GU14 0FB (hereinafter referred to as "BMW") provides the customer with certain vehicle-related information and assistance functions (hereinafter called "Services") under the name of "BMW ConnectedDrive". BMW collects, stores or processes car-related data in compliance with applicable law and only to the extent necessary to provide the Services. BMW does not collect, store or process personal data in course of the Services – except where this is explicitly stated in the service description of the individual Services. In the case of Services that require personal data to be collected, stored and processed so that such Services can actually be provided, BMW informs customers of this in advance by providing this data protection notice. The Services are provided by means of a SIM card installed in the vehicle.

AVAILABILITY OF THE SERVICE

The complete range of Services is only available for customers whose vehicles are approved in United Kingdom, and only within United Kingdom.

"BMW Emergency Call" is available to customers in United Kingdom, Germany, Austria, Italy, San Marino, Vatican, France, Monaco, Switzerland, Liechtenstein, Belgium, Luxembourg, the Netherlands, Ireland, Spain, Andorra, Portugal, Sweden, Norway, Czech Republic, Poland, Turkey and Russia "TeleServices", "Concierge services", "Remote Services" and "BMW Online" can be accessed on any mobile communication network in Europe. When used abroad, the range and characteristics of the service may vary from the range and characteristics described above and may vary from country to country. "Real Time Traffic Information" is available in United Kingdom, Germany, Austria, Italy, France, the Netherlands, Switzerland, Belgium, Republic of Ireland, Spain, Portugal, Sweden and Norway. "Online Entertainment" is available for use in United Kingdom, Germany, France, Italy, Spain, Belgium, Luxembourg, the Netherlands, Austria and Switzerland.

DEACTIVATION

You can have the BMW ConnectedDrive services deactivated through an authorised BMW centre, a BMW subsidiary or a BMW authorised workshop at any time. This also has the consequence that aspects of the emergency call in the vehicle as well as all remaining Services will no longer function.

You can additionally arrange for the remaining Services to be deactivated via "My BMW ConnectedDrive".

If the vehicle is equipped with the legally required EU Emergency Call (as from April 2018) a deactivation of the BMW ConnectedDrive basic services will not deactivate the vehicle's built-in SIM card. It has to remain active, so that the EU Emergency Call is functional all the time.

Services that are available and active without runtime limitations, cannot be guaranteed for permanent usage due to potential future technical developments (of the Service availability and/or Smartphone compatibility/operating systems).

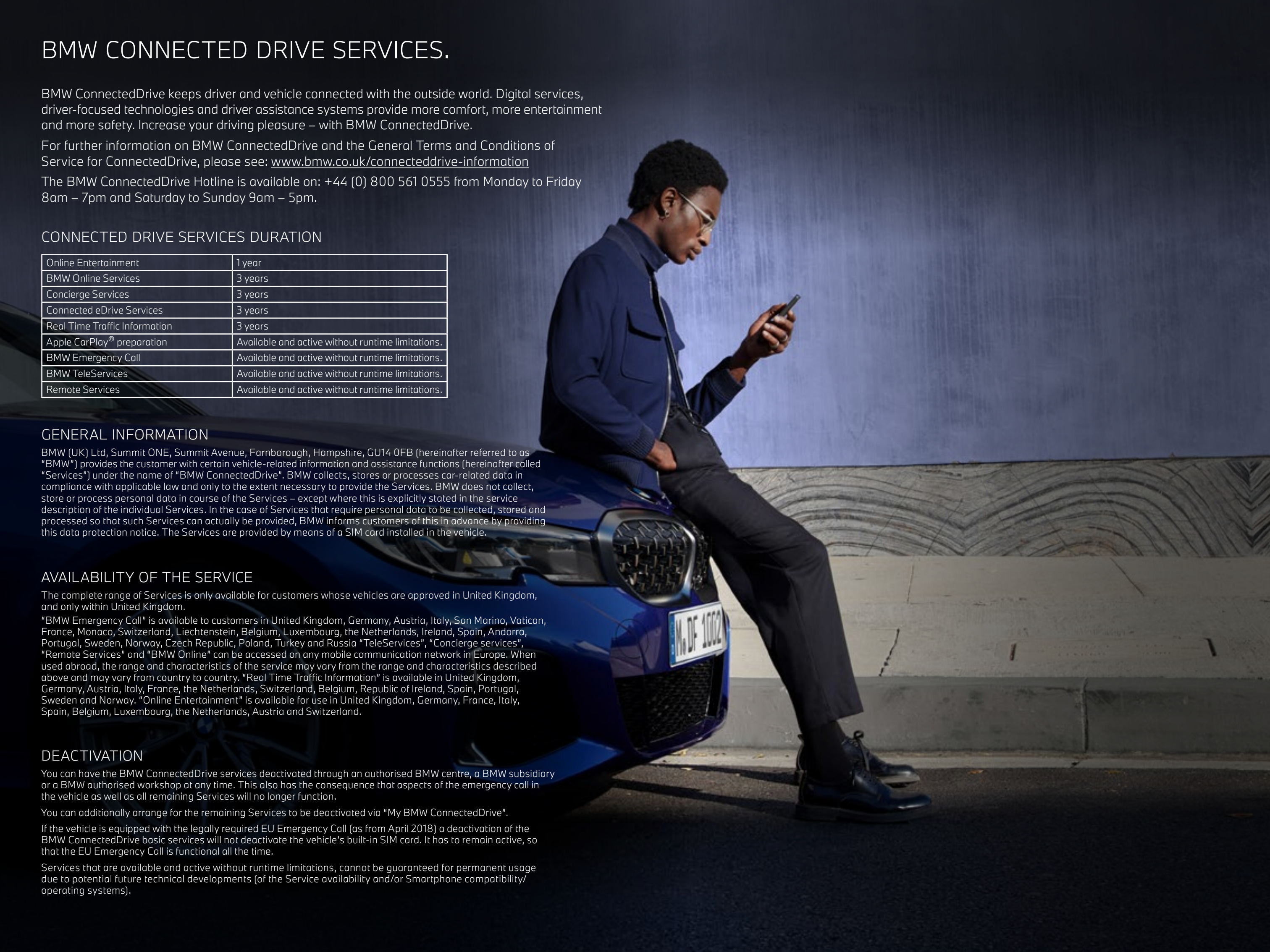



READY TO TAKE THE NEXT STEP?

